

Model EX-R5-A Turning Rolls

Roll to Roll Adjustment Chart

Maximum Work-Piece Diameter 120 inches / 3048 mm

Minimum Work-Piece Diameter 11.8 inches / 300 mm

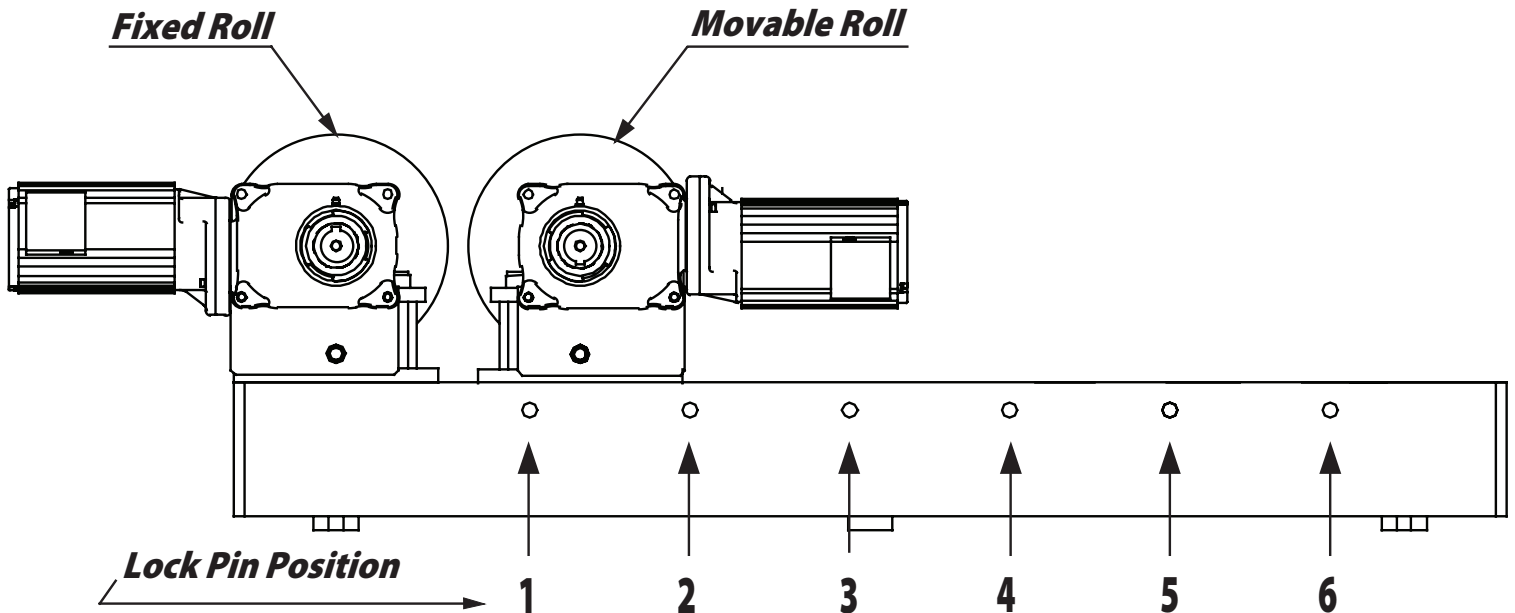

Lock Pin Position	Work-Piece Diameter (Inches)	Work-Piece Diameter (mm)
1	11.8 up to 23.6	300 up to 600
2	23.6 up to 39.4	600 up to 1000
3	39.4 up to 57.1	1000 up to 1450
4	57.1 up to 70.9	1450 up to 1800
5	70.9 up to 86.6	1800 up to 2200
6	86.6 up to 120 Max.	2200 up to 3048 Max.

⚠ Warning – Always adjust the roll to roll distance according to the size of the work-piece (tank or pipe) diameter, refer to the above chart and operating manual. Failure to use the proper pin position could result in work-piece coming off of the turning rolls causing property damage and/or injury. After adjusting roll to roll distance make sure to insert lock pin. **Never** attempt to adjust the roll to roll distance with the work-piece loaded on the turning rolls.